

# A case for innovative thinking: Expanding the boundaries of environmental protection as a result of energy design efficiencies in expeditionary yachts

Mark W. CORSETTI<sup>a,1</sup>, Capt. USNR (ret) Richard DELPIZZO<sup>b</sup>

<sup>a</sup>Director, Specialty Vessels, American Bureau of Shipping (ABS)

<sup>b</sup>Director, International Government Services, American Bureau of Shipping (ABS);  
F(SNAME)

**Abstract:** Yachts enjoy a history of development and advancement, as all it takes is a vision of what can be, belief that it can be done and the persistence and drive to make it happen. Demands for exploration are expanding. Conventional yacht design & technology will no longer be enough. Hybrid power generation, using renewable energy resources and efficiencies are the solutions to tomorrow's expedition and adventure yachts. New technologies capital and operational expenses (CAPEX and OPEX) do not include intangibles such as emissions reductions, back-up power options, reliability, flexibility, and sustainability; in addition, corporate social responsibility cannot easily be quantified or qualified. Emerging hybrid power generators such as hydrogen fuel cells can supply efficient, clean power for a wide range of fluctuating loads. However, energy generation technology without advances in energy storage systems are meaningless; so hybrid technology enablers - such as power electronics and lithium-ion batteries - help to optimize fuel efficiency, enhance system protection, reduce vessel operating costs, improve safety and control systems, reduce emissions and could save weight and space. Energy generation and storage technology are pushing the boundaries of scalability, offering yacht owners options never before dreamed. The future of expedition and adventure yacht design is only limited by imagination.

**Key Words:** Efficiencies, Fuel Cells, Hybrid, Yachts

## 1. Introduction

Yachts have enjoyed a singular history of development and advancement. Much more so than conventional vessels as it takes neither market conditions, nor commercially developed technological advances to push the boundaries of what can be made possible. All it takes is a vision of what can be, belief that it can be done and the persistence, drive and resources to bring it to reality.

Our changing, evolving and ever more connected world have promoted, nay driven, the demand by individuals for the option of exploration. Not exploration to places seen by the many - the cruise ships or the large tour operators - but exploration to places and

locations seen by the very, very few. Those places which are only accessible by privately owned craft, with the capabilities, equipment, technology and range to reach them. The traditional mechanisms of conventional propulsion for yacht design & technology will no longer be sufficient to permit these exploring yachts to travel to such remote locations. Cutting edge energy generation, storage and drive systems are the methods by which such travel can be accomplished; they are the new frontier in high-end ship design. Hybrid power generation, using renewable energy resources and efficiencies heretofore unheard of are the solutions to tomorrow's expedition and adventure yachts.

## **2. Innovation**

Hybrid solutions bring with them advantages such as: Optimization of the electrical power distribution system; Compliance with emissions regulations in environmentally sensitive areas; and Enhanced safety response to emergency scenarios (backup). However, these innovative systems come with challenges as well, such as the lack of existing requirements and international standards; these are still in developing. In addition, the complexity required to include these aspects to current designs offers a further challenge to assessing them using traditional design tools and requirements.

Hybrid solutions continue to make greater forays into yacht design due to technology enablers and technological advances in power electronics. The hardware and software that can control the energy throughout all operational phases include long life, quick-charging Li-Ion batteries; DC distribution equipment; DC hybrid systems; and an automated energy management system.

Hybrid solutions bring to the design table performance gains in a spectrum of areas. Fuel efficiency (due to optimal running conditions) contributing to reduced vessel operating cost, enhanced system protection and automation, improved safety and control systems, as well as reduced emissions and weight/space savings are all goals that may be attained through proper and informed decisions made throughout the design and construction phases.

Regardless of the technologies enabling energy generation, these would be less effective without being coupled with significant advances in energy storage systems. Energy storage systems bring their own inherent advantages to yacht design: Load levelling and peak-shaving (to help maintain a near-constant generator load; Pairing with variable speed electrical motors to allow for lower speeds (using batteries) in port, during transit or in zero emission areas; and a quick additional power source for standby power source, blackout prevention, emergency sources of power and to smooth demand for other transient power needs.

Lithium Ion Battery technology progress alone has advanced at rates that can only be described as exponential, as they have been applied to industries as varied as mobile phone, automotive and marine products. Offering the advantages of higher specific energy (Wh/kg) when compared to other battery types, as well as higher cycle life (impacted by depth of discharge), lighter weights than previous designs, faster charging with lower internal resistance, and comparatively low self-discharge when compared to other energy storage devices, these batteries have become the preferred choice among early adapters for hybrid power storage. In addition to these many advantages, they already offer low maintenance, and have improved the detrimental effects of memory effect common to earlier lithium ion batteries typically used in the nineties and early 21<sup>st</sup>

century (a common concern when recharging batteries used particularly for applications such as phones or power tools).

As with every new technology, CAPEX (capital expenses) and OPEX (operational expenses) are typically greater for these hybrid solutions than for existing power methods. In addition, intangibles such as emissions reductions, back-up power options, reliability, flexibility, sustainability; as well as corporate social responsibility, cannot easily be quantified or qualified, adding a further degree of complexity when performing analyses of alternatives to consider hybrid options.

Lastly, lest we forget the most important part of the equation for any new technologies, we need to take into account the interface between those who operate these yachts and the technology they must deal with. It is one thing to strive for technology to enable us to venture further afield than ever before. While the machinery, electronics and materials may enable this, it is worthless without the educated, trained and thoughtful personnel to operate such vessels. Owners will no longer be afforded the luxury of simply hiring a crew trained for conventionally propelled vessels. The yacht crew of the future will not only need to know the strengths and limitations (if any) of technologically enhanced vessels but also need to have the skills, knowledge and ability to maintain, repair and bring the full potential of this equipment to reality.

### 3. Energy Generating Technology

One of the most promising energy generating technologies which has already seen a number of applications on land and sea other several decades has been fuel cells. A fuel cell is a device that uses chemical fuel to produce direct current electricity, performing not unlike a battery / engine combination. Similar to a battery, it produces direct current electricity through an electrochemical process. Indeed, if one were to review the components of a fuel cell, to the untrained eye they would seem quite similar to a battery: an anode and cathode acting as electrodes to either side, with an electrolyte between the electrodes (Fig. 1).

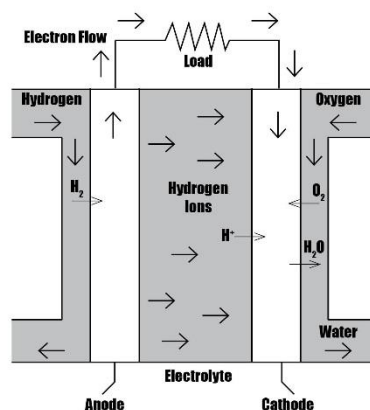

**Figure 1.** Cross Section of a Simple Fuel Cell

However, unlike a traditional battery, it cannot store energy, it can only generate it similar to how an engine does using fuel. The fuel, which is supplied externally and

combines with oxygen (typically air), completes the electro-chemical process to generate electricity (specifically energy conversion from stored chemical energy of the fuel into electrical energy). Also in contrast to a battery, a fuel cell continues to generate electricity so long as fuel and an oxidant (such as oxygen or air) are supplied; a battery will eventually lose its charge and need to be recharged. Key differences between a fuel cell and engine exist as well. Internal combustion engines or gas turbines use at least three (3) intermediate energy conversion processes. First, fuel is first burned (chemical energy of the fuel is converted to thermal energy); second, thermal energy is converted to reciprocating and rotating mechanical energy; third, mechanical energy drives a generator to convert the rotational energy into electrical energy. Energy is lost in each of these conversions which cannot be recovered. For those with a financial background, one could say that this is analogous to a financial transaction where every entity who comes in contact with the transaction takes a small percentage of the principal. By comparison, a fuel cell's single energy conversion process bypasses much of these inefficiencies, making it an inherently more efficient energy conversion process.

The most common fuel used within a fuel cell is hydrogen gas. As hydrogen is pumped into the anode side of the fuel cell, the anode will allow the hydrogen molecules to pass. Once it reaches the electrolyte, only hydrogen ions are allowed to pass through to the cathode. The valence electron of the hydrogen atom must proceed through an external electric circuit to power a load, in order to once again form with the hydrogen ion on the other side of the fuel cell. Once these electrons proceed to the cathode, it forms water through the introduction of oxygen to the hydrogen ions (protons) that journeyed through the electrolyte to the cathode. It should be pointed out that this is a simplistic explanation of fuel cell operation; more technically explicit descriptions may be found in the many fuel cell standards and guides found throughout the fuel cell manufacturing industry.

However, the Fuel Cell Power Plant cell cannot be judged solely on its operation alone. In order to better understand the overall efficiency of the fuel cell system, it must be viewed in whole. A fuel cell system (Fig. 2) includes:

1. Fuel Source;
2. Fuel Processor;
3. Means of Hydrogen Storage;
4. The Fuel Cell
5. An Inverter (if AC current is desired)

Simply put – between the marvels of electronegativity and electron affinity, man has developed ways to extract electrical energy from the molecular level and bring it to a useful form to the advancement of marine propulsion.

### *3.1. Kinds of Fuels*

But where does the hydrogen originate? One must also consider the path taken to convert a fuel into the hydrogen needed to introduce into the fuel cell. In the United States today, 95% of the hydrogen produced in the United States is made by natural gas reforming in large central plants. Natural gas reforming is an advanced and mature production process that builds upon the existing U.S. natural gas pipeline delivery infrastructure. Natural gas is mostly composed of methane, or CH<sub>4</sub>. As a hydrogen rich material, it can be used to produce hydrogen with thermal processes, such as steam-methane reformation and partial oxidation.

There are many advantages that make fuel cells desirable for marine applications:

1. General thermal efficiencies for the fuel cell itself run between 40-60%.
2. Fuel cells are relatively simple as they possess no moving parts per se. Ancillary equipment's such as pumps, compressors, and cooling, electrical and reforming equipment do add to its complexity.
3. Although some small amounts of nitrogen oxide will be generated and discharged to the environment, the overall reduction of pollutants would be far less than the typical engine combustion process.
4. For luxury yachts, quiet operations are a primary goal in the design. Noise reduction characteristics can be taken to an entirely new level with this technology.

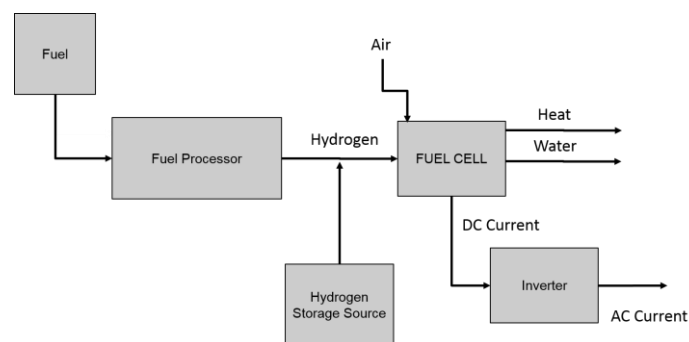

**Figure 2.** Simple Fuel Cell System

Challenges associated with fuel cells have not yet been totally eradicated, and some idiosyncrasies remain to be conquered:

1. While CAPEX costs have dropped from ten times as much as internal combustion engines to an order of magnitude of perhaps two to three times as much, this is still considerably more expensive. In addition, production of hydrogen is about four times as expensive as producing equivalent amounts of gasoline. Nonetheless, it is expected that advancements in technology, and improvements to environmental stewardship, are rarely less expensive at the onset. However, considering recent trending, it is assumed that economies of scale and greater use of the technology by pioneering operators and other early adapters will eventually drive costs downward.
2. Marine environmental criteria: fuel cells are still considered something of an evolving technology for marine use with few 'marinized' versions [tested for typical ship motion, as well as a marine environment (humidity, salt air, etc.)]. Similar challenges are found with reformer technology.
3. Transient Loads: the use of energy storage devices such as lithium-ion batteries or supercapacitors can help address the disadvantage whereby fuel cells may work very well providing steady state DC current, though not as capable as conventional engines and motors in dealing with power demand transients.
4. Non-traditional fuels: the caliber of knowledgeable crews will further raise the bar and cost of technology and improvements to environmental stewardship. Selection of onboard personnel will become of greater importance, and it can be expected that non-traditional fuels will result in increased regulation.

#### 4. Early Adapters and the SF-BREEZE Project

Since the 1990s, there have been pioneering examples of marine fuel cell use. Submarine examples include the German Type 212 class and Italian Todaro class submarines, which use a Polymer Electrolyte Membrane (PEM) fuel cell plant developed by Howaldtswerke-Deutsche Werft AG (HDW). The Type 212 class has the distinction of being the first marine fuel cell power plant in series production. While using diesel power for surface operation, its air independent propulsion system consists of 9 Siemens PEM Fuel Cells modules, each module producing 30 to 50 kW each. The improved, larger Type 214 class uses PEM fuel cells with an increased power output of 120 kW per module. While other submarine designs are reported to have fuel cell plants either in the planning or in production, such as Indian and French Navy versions of the Scorpène Class, or the Russian Navy Project 677 Lada class, little information is available. Elsewhere in submersible technology, JAMSTEC (Japan Agency for Marine-Earth Science and Technology) built the world's first deep sea probe run on fuel cells, operational in 2005. The 10m long torpedo-shaped Autonomous Underwater Vehicle (AUV), named Urashima, was designed to dive as deep as 3,500m with a cruising range of up to 300 kilometers.

On the maritime surface ship front, recent projects have been led by:

1. CMAL (Caledonian Maritime Assets Ltd), a ferry company operating 30 units, which is studying a design for a zero emission hydrogen FC ferry.
2. The M/V Undine operated by Wallenius Lines, which installed a Wartsila WFC 20 SOFC running on methanol in 2011 as part of its 'METHAPU' Consortium (Wärtsilä, Wallenius Marine, Lloyd's Register, Det Norske Veritas, and the University of Genoa).
3. Other large-scale marine concepts that have been tested include FELICITAS (2005-2008) and MC-WAP (2005-2011).
4. One of the largest fuel cells installed and operated was on the Viking Lady (2012), which utilized a 330 kW fuel cell operating for 7000 hours operation. This was done under the Norway-based FellowSHIP (DNV, Wartsila, Eidesvik).

In the United States, the Maritime Administration has worked as a partner with industry on several fuel cell projects. Principal among these has been the Hydrogen Fuel Cell Project at Honolulu Harbor and the SF-BREEZE Project.

##### 4.1. The Maritime Hydrogen Fuel Cell Project

Hydrogen fuel cells have a long track record of supplying efficient, clean power for a wide range of applications in ports, including forklifts, emergency backup systems, and vehicles; this has been demonstrated in the ports of Hamburg, Helsinki, and Los Angeles/Long Beach. An analysis by Sandia National Laboratories and the Department of Energy showed that, due to fluctuating loads in maritime auxiliary power applications, a hydrogen fuel cell (which follows the load), is more energy efficient than a comparable diesel engine. This is because a hydrogen fuel cell only supplies power when it is needed. The Maritime Hydrogen Fuel Cell Project was a demonstration of this analysis in a commercial port setting.

The project began its field trials in August 2015 with a six-month deployment hosted by Young Brothers Ltd., a subsidiary of Foss Maritime Co., at its facility in the Honolulu Harbor. The U.S. Department of Energy's Fuel Cell Technologies Office and the U.S. Department of Transportation's Maritime Administration (MARAD) co-funding the

pilot. It is hoped that the pilot hydrogen fuel cell unit will eventually replace diesel generators currently used to provide power for refrigerated containers on land and on transport barges. Hydrogenics Corp. designed and manufactured a containerized 100-kilowatt hydrogen fuel cell unit, which included the fuel cell engine, a hydrogen storage system, and power-conversion equipment. Built into a standard shipping container, the unit had an outward appearance and functionality similar to maritime diesel generators that are currently in use.

As the primary inter-island shipper of goods within Hawaii, Young Brothers Ltd. had a strong environmental and financial interest in the project. After initially using the hydrogen fuel cell unit on land, Young Brothers Ltd. Hoped to deploy the unit to power refrigerated containers onboard barges traveling between the Honolulu and Kahului harbors. During the six-month deployment, performance feedback and data was collected to determine the environmental, energy, and cost savings from the hydrogen fuel cell unit. Sandia analyzed the operational, safety, and cost performance data to develop a business case for using hydrogen fuel cells at other commercial ports. In addition, the safety aspects and feedback from the unit's design and operation may guide regulators toward formal codes and standards for hydrogen and fuel cells in maritime applications, thereby increasing the likelihood of this clean-energy technology being adopted for maritime use.

#### 4.2. *SF-BREEZE*

As noted above, fuel cell technologies have already passed the feasibility test and are found to be technically possible. This was further publicized by the 'SF-BREEZE'; the SF-BREEZE project examined the technical, regulatory, and economic feasibility of a potential high-speed passenger ferry powered solely by hydrogen fuel cells, along with its associated hydrogen fueling infrastructure planned for San Francisco Bay. SF-BREEZE stands for ***San Francisco Bay Renewable Energy Electric Vessel with Zero Emissions***. The concept of SF-BREEZE originated with the Red and White Fleet, a tour boat company founded in San Francisco, CA. The fuel cell concept was a bold move to attempt to do away with all emissions for one of their ferry boats. As these vessels are workhorses that are relied upon for shuttling hundreds of commuters every day, high speed was critical. The concept built around a 150 passenger ferry, traveling a top speed of 35 knots on four 50-mile round trip routes.

The cutting edge technologies needed to design a fuel cell plant for high speed were brought to reality through a close collaboration between the naval architect Elliott Bay Design Group, MARAD, the United States Coast Guard and the American Bureau of Shipping (ABS). Currently, the program has passed the milestone of Feasibility Study. Feasibility studies are similar to a courtroom in that they act as a crucible, to burn away irrelevancies until we are left with accurate knowledge and understanding. The evaluation performed by both the US Coast Guard and the American Bureau of Shipping did not reveal any insurmountable regulatory obstacles to deployment, at the level of details of this design phase.

We know that hydrogen fuel cells are heavier than diesel engines for a given power output, so achieving the right power-to-weight ratio for vessels is a challenge. We further know that currently, a hydrogen powered vessel may cost upwards of twice as much as a comparable diesel vessel based on today's prices, with much of the increased cost derived from the fuel cell system. We note that current technology of fuel cells cannot achieve economic parity with a comparable diesel propulsion and that a constant

examination of tradeoffs between speed / costs / emissions (among other factors) will be a background consideration on every project. These commercial considerations affect the industry at large; however, our yacht industry may be the right arena for this technology to be proven viable.

## **5. Summary**

Yachts energy generation and storage technology development and advancements continue. Technological advances in these areas are pushing the boundaries of scalability, offering yacht owners options not even dreamed of in years past. As innovations continue towards reality, the future of expedition and adventure yacht design is only limited by imagination.

## **References**

- [1] SANDIA REPORT, SAND2016-9719. Approved for public release, further dissemination unlimited.
- [2] American Bureau of Shipping. (© 2017). ABS Advisory on Hybrid Electric Power Systems
- [3] Bolind, Alan Michael. An Evaluation of Fuel Cells for Commercial Ship Applications. Society of Naval Architects and Marine Engineers (SNAME). Technical and Research Report (T&R) 55 (2000).
- [4] Delpizzo, Richard D. (2015, December) Fuel Cells at Sea. ASNE Professional Development Webinar Series.
- [5] Delpizzo, Richard D. (2018, January) Hybrid Electric Power Systems. ATENA (Associazione Italiana Di Tecnica Navale), Trieste Italy.
- [6] Ghirardo, Federico; Santin, Marco; Traverso, Alberto; Massardo; Aristide. (2011, January) Heat Recovery Options for Onboard Fuel Cell Systems. TPG-DIMSET, University of Genoa, Genoa, Italy.
- [7] U.S. Department of Energy. Office of Energy Efficiency and Renewable Energy, Fuel Cell Technologies Office. Comparison of Fuel Cell Technologies. Retrieved March 05, 2018, from <https://www.energy.gov/eere/fuelcells/comparison-fuel-cell-technologies>
- [8] U.S. Department of Energy. Office of Energy Efficiency and Renewable Energy, Fuel Cell Technologies Office. Hydrogen Production: Natural Gas Reforming. Retrieved March 05, 2018, from <https://www.energy.gov/eere/fuelcells/hydrogen-production-natural-gas-reforming>