

# Innovative Material Design for Marine Engine Non-Structural Components

Serena BERTAGNA<sup>a,1</sup>, Erik LAURINI<sup>a</sup>, Alberto MARINÒ<sup>a</sup>, Sabrina PRICL<sup>a</sup> and Vittorio BUCCI<sup>a</sup>

<sup>a</sup>*Department of Engineering and Architecture, University of Trieste*

**Abstract.** Marine engine industry is in the quest for continuous improvement of efficiency and performance. Currently, all components involved in marine engine construction are made in metallic alloys. In order to reduce costs and weight, new materials for non-structural components must be identified. The introduction of new materials, e.g., nano-engineered thermoplastic polymers (NETP), will allow additional benefits due to drastic weight reduction and simplified maintenance and inspection operations. Advancements in NETP design and application in marine engine industry relies on computer-assisted multiscale material design (CAMMD). Indeed, by advanced CAMMD techniques, the structure of NETP materials can be tailor-fitted to achieve the expected performances required by specific, advanced applications. Since the introduction of plastic materials in the construction of non-structural components for marine engines constitutes an element of great innovation, a specific rule framework must be defined yet. In this paper, starting from the analysis of the regulatory context currently used for metallic alloys a certification procedure is proposed and applied to a case study related to the cylinder head cover of a four-stroke marine engine. In particular, the mechanical properties of a new NETP material designed by CAMMD have been verified through a finite element simulation carried out on the relevant model.

**Keywords.** Marine engines, Marine engineering, Material design, Polymers, Composites, Plastic components

## 1. Introduction

In recent years, plastic materials have been applied widely in the construction of automotive components. At first, advanced plastics were used only to realize cars' body parts; now, recent studies [1][2][3][4][5][6][7] have highlighted the possibility of using these materials also in the construction of engine components. The most important benefits offered from advanced plastics are the low density and the great ease of processing [8][9]. Plastic components present the advantages of lightweight and lower production costs, if compared to metal components. Moreover, the computer-assisted design of new, nano-engineered plastics has further fostered the application of these materials for advanced performances and applications.

Acknowledging the benefits offered by plastic engineering, also the marine engine industry has been developing a great interest in its application. The introduction of advanced plastic materials represents a great innovation, since all marine engine

---

<sup>1</sup> Serena Bertagna, Department of Engineering and Architecture, University of Trieste, via A. Valerio, 10, I-34127 Trieste; e-mail: sbertagna@units.it

components are currently made of metallic alloys. As a consequence, the current regulatory framework [10][11][12][13][14] does not provide a specific rule set about the usage of plastic in machinery spaces.

In this paper, an analysis of the current requirements regarding materials usable in ship's machinery spaces and fire prevention has been carried out, in order to provide a classification procedure [15][16][17] for non-structural plastic components of marine engines. Besides, the computer-assisted multiscale material design techniques have been used to carry out molecular simulation for the prediction of the mechanical properties of the nanocomposite system [18][19][20][21]. Eventually, the output of the CAMMD design process have been used as input for finite element (FEM) simulations of a non-structural marine engine component, i.e. the cylinder head cover of a four-stroke marine engine.

## **2. Rule framework**

The Rules to be considered in the classification procedure for the application of non-metallic materials in the construction of non-structural components of marine engines are part of an undefined regulatory framework; as a matter of fact, the requirements provided by the various institutions are very complex, fragmented and not of univocal interpretation.

The analysis started from the requirements provided by the International Maritime Organization (IMO) in the "International Convention for Safety of Life at Sea" (SOLAS) [10], with reference to the "Fire Test Procedure Code" (FTP Code) [11] for the material classification. In particular, SOLAS imposes a restricted use of combustible materials, allowed only in restricted ship areas such as accommodation and service spaces. Anyhow, the ignitability of combustible materials applied shall be restricted. The use of combustible materials in machinery spaces is not allowed; therefore, the feasible plastic materials chosen to build non-structural marine engine components have to belong to the non-combustible material class. Regarding the non-combustibility tests, they have to be carried out in accordance with the requirements provided by the FTP Code. Specifically, the Annex I of the Code explains the methodology for conducting the non-combustibility and the smoke and toxic gas generation tests.

Besides the requirements issued by the IMO, their interpretations provided by the International Association of Classification Societies (IACS) must be considered. A significant manifestation of interest by the shipbuilding industry about the metal replacement in the construction of non-structural components of marine engines is provided by the recent IACS publication "Unified Interpretation of the SOLAS Convention" [12]. It refers to the "SOLAS Regulation II – 2" and to "MSC.1/Circ.1321, Guidelines for measurements to Prevent Fires in Engine-rooms and Cargo pump-rooms, Part 2, Chapter 2". The document asserts that the usage of materials other than steel can be assessed in relation to the risk of fire associated with the component and its installation. The use of different materials can be allowed for components such as machinery covers, rocker box covers, camshaft end covers, inspection plates and sump tanks, that are exactly the components proposed in the current study.

About the material classification, the "UL 94 Standard for Safety of Flammability of Plastics Materials for Parts in Devices and Appliances testing" [13] issued from the

Thermoplastic Testing Centre can be considered, in addition to the FTP Code. It consists of a plastic flammability standard which determines the material's tendency to either extinguish or spread the flame once the specimen has been ignited. Regarding the materials under analysis, six classifications are provided, that are the Horizontal Burning Test HB, the 20 mm Vertical Burning Test V-0, V-1, V-2 and the 125 mm vertical Burning Test 5VA or 5VB. Depending on the relevant test method, specimens have to be tested in both a horizontal and a vertical position and are subjected to a defined ignition flame source for a specified period of time and a specified number of times.

In order to clear the use of non-structural plastic components on marine engines, the last step of the rule framework analysis has regarded the rules issued from the classification societies. In particular, the Lloyd's Register "Rules for Manufacture, Testing and Certification of Materials" [14] provides rules for manufacture and test procedures regarding thermoplastic polymers, with approval requirements for base materials used in the construction of any associated machinery components. For its purposes, a "plastic material" is defined as an organic substance which may be thermosetting or thermoplastic and which, in its finished state, may contain reinforcements or additives. In particular, the data to be provided by the manufacturer for each thermoplastic polymers include i) melting point and melt flow index; ii) density and bulk density; iii) filler and pigment content, where applicable; and iv) colour. Specimens are to be prepared by moulding or extrusion in accordance with the polymer manufacturer's recommended conditions. The tests to be carried out on these samples include i) tensile and compressive stress at yield and break; ii) modulus of elasticity in tension; iii) tensile strain at yield and break; iv) compressive modulus; v) temperature of deflection under load; and vi) determination of water absorption. These requirements have to be applied to both pure and reinforced thermoplastic polymers.

The construction of non-structural plastic components on marine engines requires a specific classification procedure; the Registro Italiano Navale (RINA) "Guide for Technology Qualification Processes" [15] has been analysed in order to provide a systematic approach to the qualification of the new technology proposed, ensuring that it is fit for its intended service. For its purpose, the use of plastic materials in the construction of non-structural marine engine components has to be considered a novel technology, since this definition comprises the application of a proven technology in a new environment. The Technology Qualification is to be carried out through a documented process that includes examination of the design, engineering analyses and testing programs. A risk assessment is to be conducted on the base of the "Guide for Risk Analysis" [16] and the "Guide for Failure Mode and Effect Analysis" [17] issued from RINA; the risk assessment has the aim to identify, rank and control failure modes affecting the fitness for service of the technology. Besides, engineering analyses, measurements and tests are to be carried out to demonstrate and document that the novel technology fulfils the specified requirements. The Technology Qualification final result is an official statement of fitness for service. The technical reports have the aim to confirm that the novel technology meets the specified requirements for its intended service.

### 3. Material design

The idea of performing computer-assisted multiscale material design (CAMMD) starting from fundamental physical and chemical principles has an obvious appeal as a tool of potential great impact on technological innovation and material design. Briefly, the advantages of considering multiscale molecular modeling as an integral part of material design include, among others i) the reduction of the product development time by alleviating costly trial-and-error iterations; ii) the reduction of product costs through innovations in materials, products, and process design; iii) the reduction of the number of costly, large-scale experiments; iv) the increase of product quality and performance by providing more accurate predictions in response to material design requirements and loads; and v) the support provided to conceive and develop entirely new materials.

In this work, the CAMMD concept has been applied to estimate specific thermophysical and mechanical properties of NETP systems suitable to be employed in the fabrication of head covers for marine engines. To the purpose, molecular dynamics (MD) simulation procedures have been developed to predict density and glass transition temperature as a function of filler concentration in a thermoplastic matrix [18]. Also, other MD-based recipes have been elaborated to determine mechanical properties such as stress-strain curves and the Young modulus [18-20] of selected NETP systems. In what follows, the results of the application of these CAMMD-based procedures to the specific industrial problem is discussed.

Based on the specific material requirements, a preliminary literature survey combined with the application of Ashby's method [21] identified polyamide-6,6/glass fiber (PA66/GF)-based NETPs as the most suitable systems for the context application. The computational recipes summarized above were then applied to predict the mechanical properties of PA66/GF NETPs as function of GF content.

According to the simulations (Figure 1), the addition of glass fibers (15-50 % wt) to the PA66 matrix results in a remarkable increase of the predicted Young modulus  $E$  for the corresponding NETPs (Figure 1A). The relative increment of  $E$  with respect to the pristine PA66 polymer is well evident from the behavior of the corresponding enhancement factor  $E_f$  shown in Figure 1B. These results, coupled with further economical and environmental considerations, led to the NETP based on PA66 loaded with 30 % wt glass fiber as the system of choice.

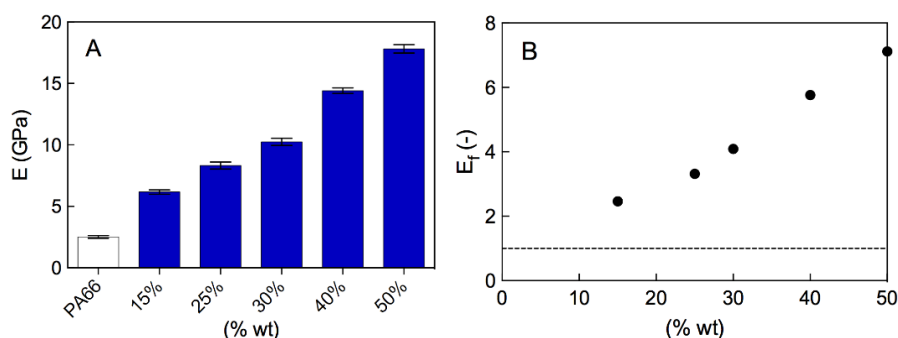

**Figure 1.** (A) Predicted Young modulus  $E$  for the pristine PA66 matrix and for the relevant PA66/GF NETPs as a function of fiber content (% wt). (B) Enhancement factor  $E_f (= E_{NETP}/E_{PA66})$  for the systems in panel A.

Accordingly, Table 1 lists the numerical values of the entire set of properties estimated for this system and those for the pure PA66 matrix for comparison.

**Table 1.** Values of the mechanical and thermophysical properties for the PA66/GF (30 % wt) as estimated by CAMMD at room temperature. The corresponding values predicted for the pristine PA66 matrix are also shown for comparison.

Property	PA66/GF (30 % wt)	PA66
Young modulus (E, GPa)	10.2 ± 0.5	2.6 ± 0.2
Density (d, g/cc)	1.32 ± 0.03	1.15 ± 0.02
Glass transition temperature (T <sub>g</sub> , °C)	50 ± 2	52 ± 3
Strain at break (%)	4 ± 0.2	5 ± 0.5
Stress at break (MPa)	189 ± 6	81 ± 4

As seen from this Table, the predicted glass transition temperature (T<sub>g</sub>) of the thermoplastic PA66 (52 °C) is practically unaffected by the 30% wt GF dispersion (50 °C), as is the value of the strain at break (0.05 and 0.04, respectively). On the contrary, the addition of GF to the PA66 matrix results in an increase of both the maximum strain at break (189 MPa) and the Young modulus (10.2 GPa) values.

#### 4. Case study

The cylinder head cover of a four-stroke marine engine (Figure 2), currently made of aluminium, has been considered to carry out the finite element simulation.

This component can be classified as a non-structural element, since its main purpose is to protect the mechanical tappets and the injectors from external dust and contain any oil losses from valve mechanisms. Normally, the cylinder head cover is not subjected to static and dynamic loads except during maintenance and inspection operations. However, the component could be exposed to acid substances in both liquid and aerial form and has to face with a variable thermal load.

##### 4.1. Cylinder head cover model

On the basis of the results obtained from the computer-assisted multiscale material design, the PA66/GF (30% wt) has been selected to perform the finite element simulation. The application of the new material to the cylinder head cover has required the redesign of the component; this phase has been carried out with the aim to both ensure the same structural resistance and simplify the cover removal procedure, maintaining the same fixing points of the current element in order not to modify the engine head configuration.

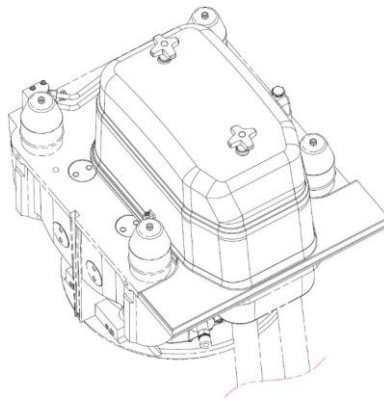

**Figure 2.** Aluminium cylinder head cover.

The new model presents two main parts, an aluminium collar plate and a plastic lid. The collar plate has the aim to fix the cover to the engine hotbox through five bolts. The cover lid is the element with the purpose of protecting the mechanisms of the cylinders. The internal face of the lid is equipped with a grid in order to ensure the structural integrity. The reinforcements run along all the interior length of the element, creating a “U” shape without interruptions, and are connected to the cover frame in order to redistribute the load on the whole perimeter. Furthermore, in order to simplify the cover removal, the model presents two handles on the top of the lid.

#### 4.2. Finite element simulation

The model has been meshed through an unstructured grid employing tetrahedral solid elements. The mesh has been intensified in proximity of geometry changes and in correspondences of curves. The maximum size of the single element has been set equal to the maximum plastic thickness.

The model has been considered as totally supported since the cylinder head cover is normally fixed to the engine hotbox. The constraint has been applied on the lower face of the collar plate and blocks all the degrees of freedom. Furthermore, sliding and separation between faces have been avoided through considering all the surfaces in contact.

The model has been tested under the application of a static load. In particular, the load case analysed considers a load applied on the lid of the cover. This analysis has the aim to simulate maintenance and inspection operations, in which a surveyor is supposed to walk on the cover. In order to represent this situation, a vertical load equal to 200 kg has been applied, distributed equally on the footprints (Figure 3).

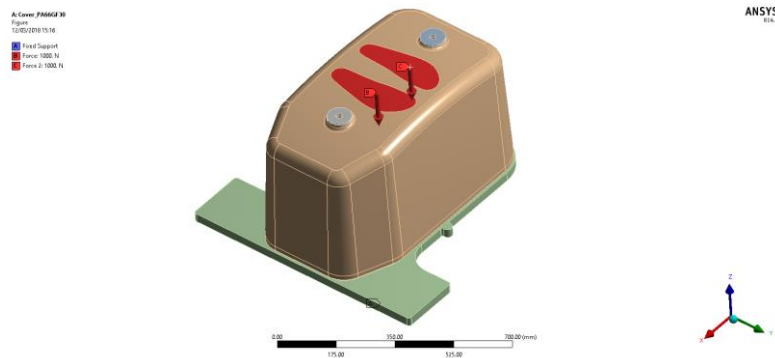

Figure 3. Load case.

#### 4.3. Results

The results obtained from the FEM simulation are reported in Table 2. The maximum displacement is limited and located at the center of the cover lid and the maximum stress and strain results are far lower than the acceptable limits.

Table 2. Values of deformation, stress and strain as estimated by the finite element simulation.

TOTAL DEFORMATION, STRESS AND STRAIN	
Total Deformation (mm)	0.440
Equivalent (von-Mises) Stress (MPa)	8.51
Equivalent Elastic Strain (%)	8.35e-04

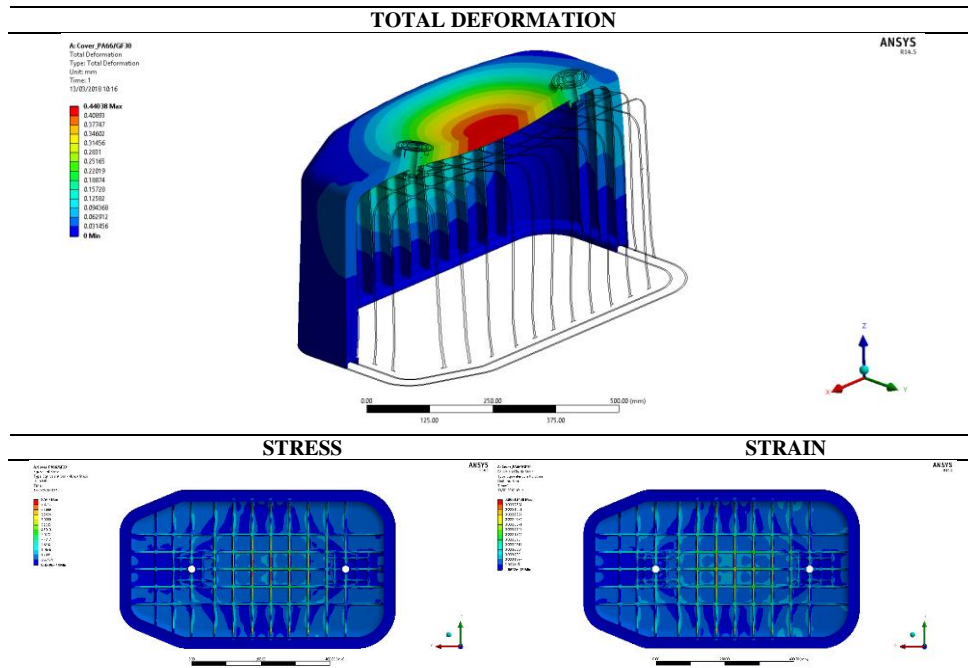

Figure 4. Total deformation, stress and strain graphic results.

## 5. Conclusion

The submitted study has been aimed to verify the possibility of using innovative plastic materials in the construction of non-structural marine engine components.

The most important advantages offered by the replacement of steel materials with the plastics under analysis are the cost saving and the lower weight of the element. On the base of some estimates, realizing the cylinder head cover proposed within the study with plastic materials should lead to save about the 70 percent of the component price. About the second benefit, the gain in terms of weight should be about the 50 percent, since the density of plastic materials is approximately the half of the density of the metallic material currently used, i.e. aluminium.

The analysis of the current regulatory context has been carried out with the aim to propose a classification procedure for plastic components, in order to make the usage of the materials under investigation compliant with the regulations required by the classification societies. This has highlighted that the most important property a plastic material should have, in order to be accepted by registers, is the non-combustibility. Since the aim of these plastics is to replace metallic materials in the construction of non-structural engine components, also the mechanical characteristics are of great importance.

Regarding material identification, attention has been given to fibre reinforced polymers, which represent one of the most interesting material class able to ensure both lightness and high strength. Specifically, computer-based material design has identified PA66 loaded with 30% of glass fibres as the most suitable materials for the current application.

The finite element simulation carried out on the component model has offered encouraging results, since deformation, stress and strain magnitudes are far lower than the critical values offered by the material. This analysis represents the base for the future development, which will consist of reconsidering the component design in order to propose the best solution in terms of production process and both material and cost saving.

## Acknowledgments

This work was supported by “PLASTICO – Plastic Cover for Marine Engine” research program, funded by the Regione Autonoma Friuli-Venezia-Giulia with POR-FESR 2014-2020, Asse 1 Azione 1.3.b.

## References

- [1] G.M. Candido, F.Jr. Santolia, M.R.F. De Melo, G.A.B. Dos Santos, Methodology of plastic parts development in the automotive industry, *SAE Technical Papers* (2006)
- [2] P. Mapleston, Automotive plastics: An accelerating market, *Plastics Engineering* **64** (2008), 10-16+18.
- [3] K. Friedrich, A. A. Almajid, Manufacturing Aspects of Advanced Polymer Composites for Automotive applications, *Applied Composite Materials* **20** (2013), 107-128
- [4] K. Bielefeldt, J. Walkowiak, W. Papacz, Composites and reinforced plastics in the automotive industry, *Applied Mechanics and Materials* **611** (2014), 352-357
- [5] A. Elmarakbi, *Advanced Composite Materials for Automotive Applications: Structural Integrity and Crashworthiness*, John Wiley & Sons, Ltd., Hoboken, 2014
- [6] S.A. Pradeep, R.K. Iyer, H. Kazan, S. Pilla, Automotive Applications of Plastics: Past, Present and Future, *Applied Plastics Engineering Handbook: Processing, Materials, and Applications: Second Edition* (2016), 651-673.
- [7] L.M. Sherman, Automotive plastics: New thermoplastic solutions redefine ‘performance’ from all angles, *Plastics Technology* **63** (2017), 44-47.
- [8] H. Saechtling, *Handbook Plastic Material 7<sup>th</sup> Edition*, Kunststoff-Taschenbuch, München, 1995
- [9] T.A. Osswald, G. Menges, *Materials Science of Polymers for Engineers 2<sup>nd</sup> Edition*, Hanser Gardner Publications, Valley Avenue, 2003
- [10] ..., *SOLAS Consolidated Edition 2014*, Polestar Wheatons (UK) Ltd, Exeter, 2014
- [11] ..., *Fire Test Procedure Code 2010*, MSC.307(88), International Maritime Organization, 2010
- [12] ..., *Interpretations of the International Convention for the Safety of Life at Sea (SOLAS), 1974 and its Amendments*, International Association of Classification Societies, 2018
- [13] ..., *UL Standard for Safety for Test for Flammability of Plastic Materials for Parts in Devices and Appliance, UL 94, Fifth Edition*, Underwriters Laboratories, Northbrook, 1996
- [14] ..., *Rules for the Manufacture, Testing and Certification of Materials*, Lloyd’s Register Group Limited, London, 2014
- [15] ..., *Guide for Technology Qualification Processes*, Registro Italiano Navale, Genova, 2016
- [16] ..., *Guide for Risk Analysis*, Registro Italiano Navale, Genova, 2010
- [17] ..., *Guide for Failure Mode and Effect Analysis*, Registro Italiano Navale, 2017
- [18] E. Laurini, P. Posocco, M. Fermeglia, S. Pricl, MoDeNa Nanotools: An integrated multiscale simulation workflow to predict thermophysical properties of thermoplastic polyurethanes, *Journal of Computational Science* **15** (2016), 24-33.
- [19] E. Laurini, P. Posocco, M. Fermeglia, S. Pricl, Multiscale molecular modeling of clay-polymer nanocomposites, *Clay-Polymer Nanocomposites. Morphology, Structure, Properties and Applications*, Elsevier B.V., Amsterdam, The Netherlands, 2017, 83-112.
- [20] E. Laurini, M. Fermeglia, S. Pricl, Materials by design: multiscale molecular modeling for the design of nanostructured membranes, *Membrane Engineering for the Treatment of Gases*, The Royal Society of Chemistry, London, United Kingdom, 2018, 28-49.
- [21] M. F. Ashby, *Materials Selection in Mechanical Design*, Butterworth Heinemann, Linacre House, United Kingdom, 1999.